

600
PSI

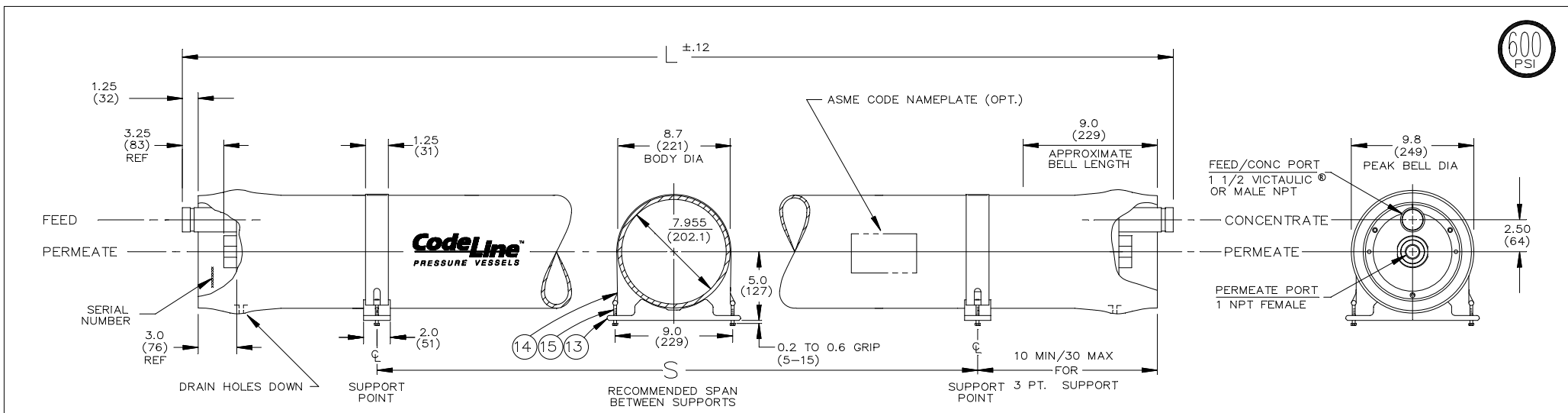

Dwg. Ref.	Qty. Per	Item Number	Description	Materials/Remarks
SHELL				
①	1		Shell	Filament wound epoxy/glass composite-Head locking grooves integrally wound in-place
HEAD				
②	2	50566	Bearing Plate	6061-T6 aluminum alloy-hard anodized
③	2	50550	Sealing Plate	PVC Thermoplastic
④	2	50567	Feed/Conc Port	Type 316 Stainless Steel
⑤	2	45090	Port Retainer Set	304 Stainless Steel, Two-piece set
⑥	2	50569	Permeate Port	PVC Thermoplastic
⑦	2	45066	Port Nut	PVC Thermoplastic-left hand thread
⑧	2	45320	Head Seal	Ethylene Propylene, Quad Ring
⑨	4	45312	Port Seal	Ethylene Propylene, O-Ring
HEAD INTERLOCK				
⑩	6	50758	Locking Ring	Cast Aluminum-hard anodized
⑪	2	50562	Securing Ring	Reinforced Plastic - Yellow Color
⑫	6	45228	Securing Screws	316 Stainless Steel
VESSEL SUPPORT				
⑬	*2	45102	Saddle	Engineering Thermoplastic
⑭	*2	45042	Strap Assy	304 Stainless Steel - PVC cushion
⑮	4	46265	Strap Screw	5/16-18 UNC, 18-8 Stainless Steel
ELEMENT INTERFACE				
⑯	2	As Required	Adapter	Engineering Thermoplastic
⑰	1	45069	Thrust Ring	Thermoplastic, White
⑱	2	45308	Adapter Seal	Ethylene Propylene - O-Ring
⑲	4	As Required	PWT Seal	Ethylene Propylene - O-Ring

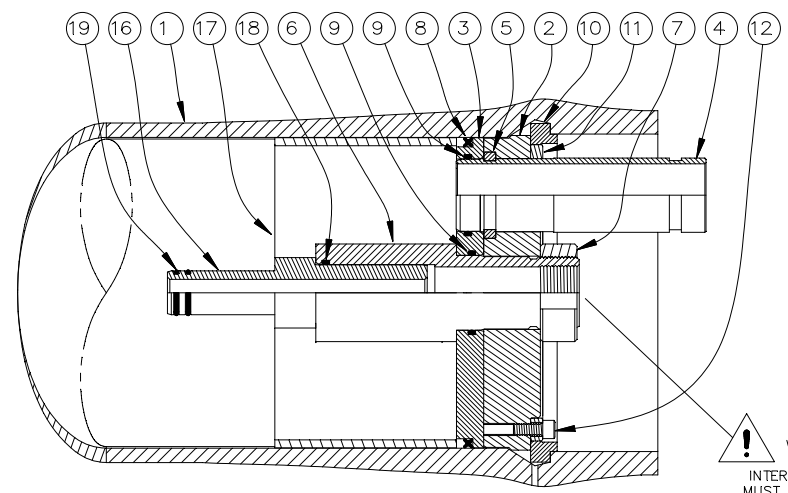

CENTER VESSEL ON 2 OR 3 SUPPORTS AS NOTED

SECTION THROUGH END CLOSURE

ITEM ⑰ DOWNSTREAM ONLY

! WARNING!
INTERNAL PORT PRESSURE MUST NOT EXCEED 125 PSI

NOTES:
• DIMENSIONS IN INCHES (MM APPROX)
• NOT TO BE USED FOR CONSTRUCTION UNLESS CERTIFIED

Shell Length Code	L L.O.A. IN (MM)	S Span IN (MM)	Empty Weight LB (KG)
1	63.0 (1600)	34 (864)	80 (36)
2	103.0 (2616)	56 (1422)	105 (48)
3	143.0 (3632)	80 (2032)	135 (61)
4	183.0 (4648)	104 (2642)	160 (73)
5	223.0 (5664)	128 (3251)	190 (86)
6	263.0 (6680)	* 3 PTS.	215 (98)
7	303.0 (7696)	* 3 PTS.	245 (111)
7.5	323.0 (8204)	* 3 PTS.	260 (118)
8	343.0 (8712)	* 3 PTS.	275 (125)

STRUCTURAL GROUP

ENGR AP 14JUN99	CODELINE MODEL E8B			
QLTY RAP 21JUN99	MEMBRANE HOUSING			
MRKT DWE 17JUN99	ECO 89768	SHEET 1 OF 1	SIZE B	NUMBER 507002
				REV P

RATING:

DESIGN PRESSURE..... 600 PSI at 120°F
 (4.1 MPa at 49°C)
 MIN. OPERATING TEMP..... 20°F
 (-7°C)
 FACTORY TEST PRESSURE..... 900 PSI
 (6.2 MPa)
 BURST PRESSURE..... 3600 PSI
 (24.8 MPa)

INTENDED USE

The Model E8BFiberglass RO Pressure Vessel is designed for continuous, long-term use as a housing for reverse osmosis membrane elements to desalt typical brackish waters at pressures up to 600 psi. Any make of eight-inch nominal diameter spiral-wound element is easily accommodated; the appropriate interfacing hardware for the element specified is furnished with the vessel.

The Model E8B is designed in accordance with the engineering standards of the Boiler and Pressure Vessel Code of the American Society of Mechanical Engineers (ASME Code). At small additional cost, vessels can be inspected during construction by an ASME Authorized Inspector and ASME Code stamped.

The Model E8B must be installed, operated and maintained in accordance with the precautions listed and good industrial practice to assure safe operation over a long service life.

The high performance reinforced plastic shell must be allowed to expand under pressure; undue restraint at support points or piping connections can cause leaks to develop in the shell. The end closure, incorporating close-fitting, interlocking metal components, must be kept dry and free of corrosion; deterioration can lead to catastrophic mechanical failure of the head.

Structural Group will assist the purchaser in determining the suitability of this standard vessel for their specific operating conditions. The final determination however, including evaluation of the standard materials of construction for compatibility with the specific corrosive environment, shall be the responsibility of the purchaser. Alternate materials with enhanced corrosion resistance are available on special order.

Specifications subject to change without notice.

PRECAUTIONS

- DO... read, understand and follow all instructions; failure to take every precaution will void warranty and may result in vessel failure
- DO... mount shell with drain holes down on horizontal members at central span "S" using compliant vessel supports furnished; tighten hold down straps just snug
- DO... provide overpressure protection for vessel set at not more than 105% of design pressure
- DO... inspect end closures regularly; replace components that have deteriorated and correct causes of corrosion
- DO... keep Port Nut tight; turn counterclockwise to tighten left hand thread
- DO NOT...make rigid piping connections to ports or clamp vessel in any way that restricts growth of fiberglass shell under pressure; ▲DIA = 0.02 in. (0.5mm) and ▲L = 0.3 in. (8mm) for a length code -6 vessel
- DO NOT...hang piping manifolds from ports or use vessel in any way to support other components; branch connection piping may be simply supported between the header and port; maximum weight of branch piping; feed/concentrate - 16 lbs (7 kg); permeate - 8 lbs (4 kg)
- DO NOT...operate vessel at pressures and temperatures in excess of its rating
- DO NOT... operate vessel without permeate ports internally connected with a complete set of elements and interconnecting hardware
- DO NOT...operate vessel with permeate pressure in excess of 125 psi at 120°F (0.9 MPa at 49°C)
- DO NOT... overtighten the connection to the permeate port (hand-tighten plus one-quarter turn, check for leaks.)
- DO NOT...tolerate leaks or allow end closures to be routinely wetted in any way
- DO NOT... pressurize vessel until double checking to verify that all three segments of Locking Ring Set are in place, and that the Securing Ring is fully seated and secured by all three Securing Screws
- DO NOT...work on any component until first verifying that pressure is relieved from vessel

For complete information on proper use of this vessel please refer to the E8 Series USER'S GUIDE, Bulletin 507011

ORDERING

Please specify the following:

- VESSEL MODEL NUMBER built from table of options below
- MEMBRANE ELEMENT MODEL NUMBER
- SPECIFIC CONCERNS regarding INTENDED USE and requests for SPECIAL MATERIALS of CONSTRUCTION

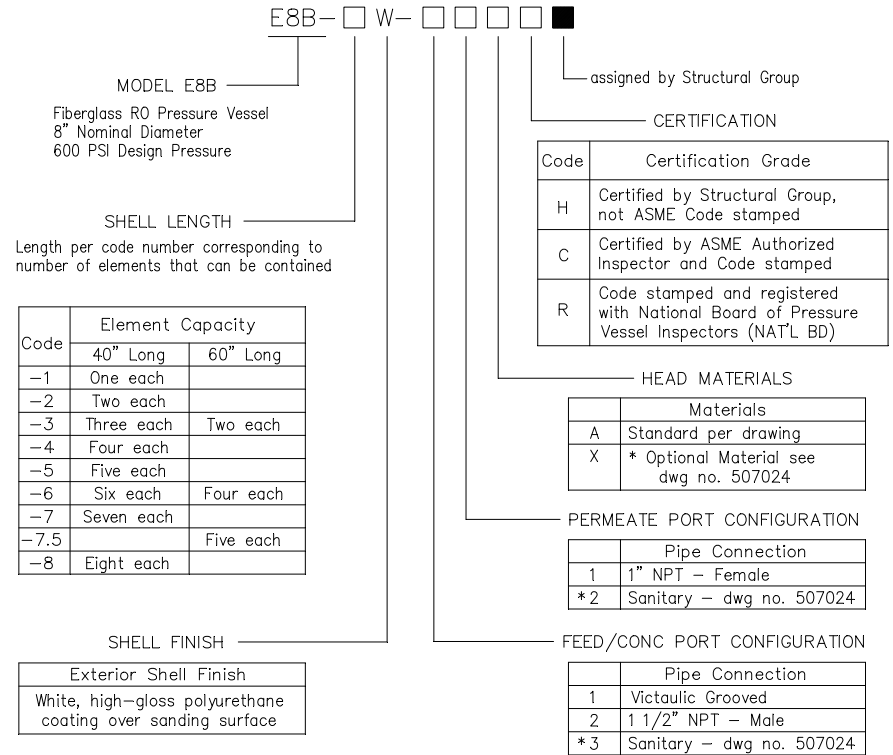

* OPTIONAL - Consult factory for specifications and pricing

