

450  
psi

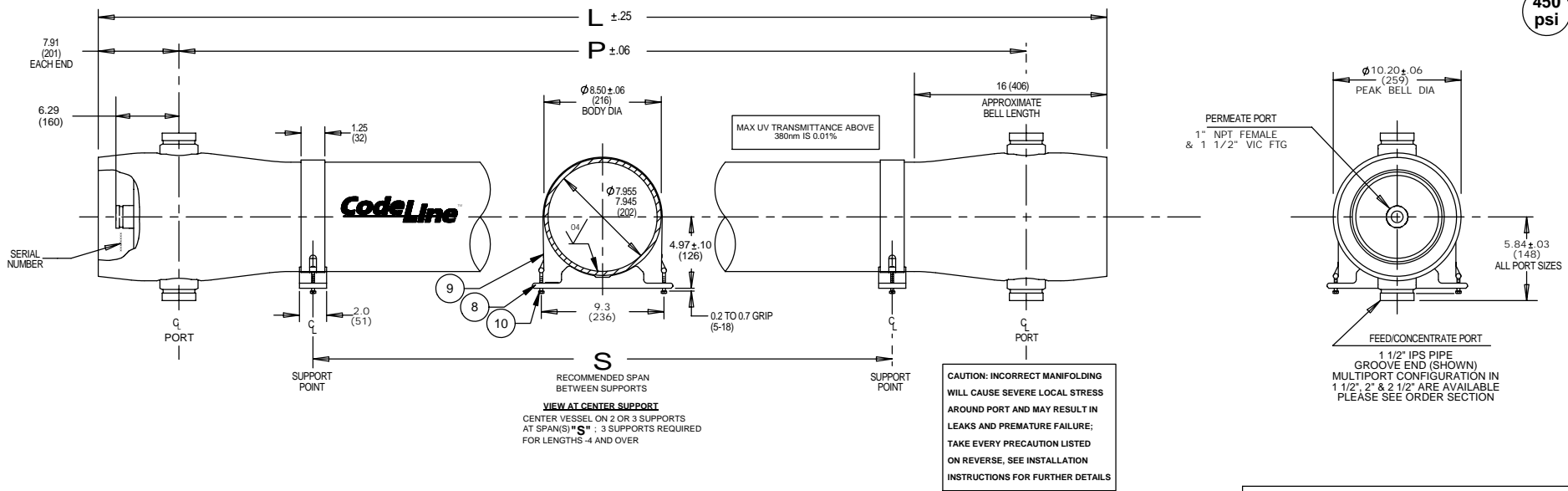

Dwg. Ref.	Qty. Per	Part Number	Description	Materials/Remarks	
SHELL					
1	1		Shell	Filament wound epoxy/glass composite-Head locking grooves integrally wound in-place.	
2	A/R	ORDER SECTION	F/C Port	CF3M	
3	A/R		F/C Port Seal	EPDM	
HEAD					
		CODE	NON-CODE	ASME CODE	NON-ASME CODE
4	2	52571	52570	Head Assy	Noryl backed with Steel Noryl
5	2	52574	52574	Head Seal	EPDM - Square Cut
6	2	52245	52245	Adapter ,seal	EPDM - O-ring
HEAD INTERLOCK					
7	2	52510	Locking Ring	Steel SA 105, Nickel Plated.	
VESSEL SUPPORT					
8	* 3	52169	Universal Saddle	Engineering Thermoplastic	
9	* 3	45042	Strap Assy	304 Stainless Steel - PVC cushion	
10	6	46265	Strap Screw	5/16-18 UNC, 18-8 Stainless Steel	
ELEMENT INTERFACE					
11	2	A/R	Adapter	Engineering Thermoplastic	
12	A/R	A/R	PWT SEAL	EPDM	
13	1	52609	Thrust Cone	Engineering Thermoplastic	

\* 2 each furnished with length code 1, 2 & 3

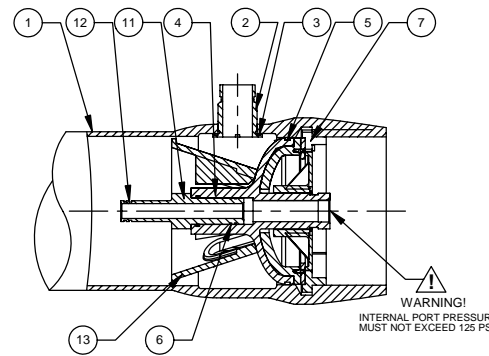
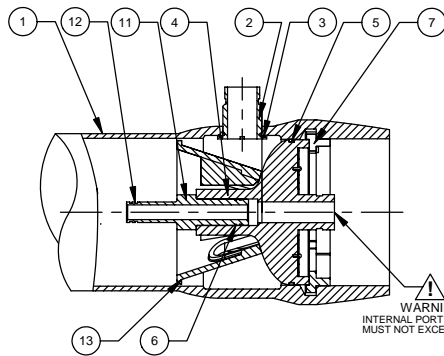

- NOTES
- MAX. ANGULAR VARIATION BETWEEN ANY PORTS ± 0.5°
  - SHELL EXTERIOR COATED WITH WHITE, HIGH GLOSS POLYURETHANE PAINT
  - DIMENSION IN INCHES (MM APPROX.)
  - NOT TO BE USED FOR CONSTRUCTION UNLESS CERTIFIED

Shell Length Code	L L.O.A. IN (MM)	P Span IN (MM)	S Span IN (MM)	Approx. Weight LB (KG)
1	63 (1600)	47.0 (1194)	28X 1 (711)	104 (47)
2	103 (2616)	87.0 (2210)	56 X 1 (1422)	126 (57)
3	143 (3632)	127.0 (3226)	80 X 1 (2032)	148 (67)
4	183 (4648)	167.0 (4242)	64 X 2 (1626)	170 (77)
5	223 (5664)	207.0 (5258)	78 X 2 (1981)	192 (87)
6	263 (6680)	247.0 (6274)	92 X 2 (2337)	214 (97)
7	303 (7696)	287.0 (7290)	106 X 2 (2692)	236 (107)



DRAWN ARB	<b>CODELINE OCTA 80R45 MEMBRANE HOUSING</b>				
CHECKED SM					
DATE 28 SEPT 04	ECN 634	SHEET 1 OF 2	SIZE A3	NUMBER 99121	REV D

**RATING:**

DESIGN PRESSURE.....450 PSIG at 190°F  
 (3.1 MPa at 88°C)  
 MIN. OPERATING TEMP.....20°F  
 (-7°C)  
 FACTORY TEST PRESSURE.... CE / ASME  
 675 PSIG / 585 PSIG  
 (4.7 MPa) (4.03 MPa)  
 QUALIFICATION PRESSURE.....2700 PSI  
 (18.62 MPa)

**INTENDED USE:**

The CodeLine OCTA 80R45 Fiberglass RO Pressure Vessel is designed for continuous, long term use as a housing for reverse osmosis membrane elements to desalt typical brackish waters at pressures up to 450 psi. Any make of eight-inch nominal diameter spiral-wound element is easily accommodated; the appropriate interfacing hardware for the element specified is furnished with the vessel.

The CodeLine OCTA 80R45 with Steel Backed Noryl Head is designed in accordance with the engineering standards of the Boiler and Pressure Vessel Code of the American Society of Mechanical Engineers (ASME) Code. At small additional cost vessels can be inspected during construction by an ASME Authorized Inspector and ASME Code stamped.

In case of membrane housing with Noryl Head, only the shell is ASME compliant.

The CodeLine OCTA 80R45 must be installed, operated and maintained in accordance with the listed precautions and good industrial practice to assure safe operation over a long service life.

The high performance Filament wound FRP shell must be allowed to expand under pressure; undue restraint at support points or piping connections can cause leaks to develop in the shell. This side-ported vessel requires special precautions in mounting and connection to piping so that the vessel will not be subjected to excessive stress due to bending moments acting at the side openings in the fiberglass shell. The end closure, incorporating close fitting, interlocking metal components, must be kept dry and free of corrosion; deterioration can lead to catastrophic mechanical failure of the head.

Pentair Water will assist the purchaser in determining the suitability of this standard vessel for their specific operating conditions. The final determination however, including evaluation of the standard material of construction for compatibility with the specific corrosive environment, shall be the responsibility of the purchaser. Alternate materials with enhanced corrosion resistance are available on special order.

Specifications are subject to change without notice.

**PRECAUTIONS:**

- DO...read, understand and follow all instructions; failure to take every precaution will void warranty and may result in vessel failure
- DO...mount the shell on horizontal members at span “S” using compliant vessel supports furnished; tighten hold down straps just snug
- DO...align and center side ports with the manifold header. Correct, causes of misalignment in a row of vessels connected to the same header
- DO...use flexible type grooved-end pipe couplings, Victaulic® Style 77 or equal, at side ports; allow full, 0.125 inch gap between port and piping, and position piping to maximize flexibility of connection.
- DO...provide flexibility in, and support for piping manifolds so that vessel can grow in length under pressure without undue restraint; provide additional flexible joints in large pipes leading to manifold header.
- DO...provide overpressure protection for vessel set at not more than 105% of design pressure
- DO...inspect end closures regularly; replace components that have deteriorated and correct causes of corrosion
- DO NOT...work on any component until first verifying that pressure is relieved from vessel
- DO NOT...make rigid piping connections to ports or clamp vessel in any way that resists growth of fiberglass shell under pressure;  
 \*\*\*ΔDIA = 0.015 in. (0.4mm) and  
 \*\*\*ΔL = 0.2 in. (6mm) for a length code –7 vessel
- DO NOT... hang piping manifolds from ports or use vessel in any way to support other components
- DO NOT...tighten Permeate Port connection more than one turn past hand tight
- DO NOT... operate vessel without connecting both Permeate Ports internally to complete set of elements or otherwise plug ports internally so that external piping connection is not subjected to feed pressure
- DO NOT...install Spacer on downstream end of vessel
- DO NOT...operate vessel without Thrust Cone installed downstream
- DO NOT...pressurize vessel until double-checking to verify that the Locking Ring is in place and fully seated.
- DO NOT...operate vessel at pressure and temperature in excess of its rating.
- DO NOT...operate vessel with permeate pressure in excess of 125 psi at 190°F (0.86 Mpa at 88°C).
- DO NOT...tolerate leaks or allow end closures to be routinely wetted in any way
- DO NOT...operate outside the pH range 3-10.

**ORDERING:**

Using the chart below, please check the features you require and fax them with your purchase order to our customer service department for further processing.  
 For optional materials and / or feature not listed below, please consult the factory for pricing and availability

**VESSEL LENGTH CODE – please check one**

MODEL OCTA 80R45  -1  -2  -3  -4  -5  -6  -7

**MEMBRANE BRAND AND MODEL – please check one and fill in information**

- Please supply adapters for the following membrane brand and specific model  
 Brand \_\_\_\_\_ Model \_\_\_\_\_
- Membrane brand and model information is not currently available, but will be supplied to Pentair Water on or before the following date. \_\_\_/\_\_\_/\_\_\_

**CERTIFICATION REQUIRED**

- ASME Stamped and National Board Registered (Please consult factory for pricing)
- CE Marked
- NSF / ANSI-61 Certified
- Standard, Certified by Pentair water .

**MATERIAL AND PORT CONFIGURATIONS OPTIONS – please check one**

- Standard: all materials and port configurations as per drawing 99121 on the previous page  
 NOTE: The options listed below will increase the vessel price. Call factory for pricing details.
- Option: Customer specified port configuration. Using the chart below, please indicate the customized options you require for each end of the pressure vessel (multiple options are available at each end).  
 (Please consult factory as these options will affect pricing and vessel lead time)

**FEED PORT CONFIGURATION**

- Standard – 1½” IPS pipe, grooved ends, with ports in-line
- Optional – Multi-Ports™  
 Using the instructions in Order Specification Sheet #99007 please fill out your feed port configuration in the space below. List port location first, followed by port size for each choice.
- 2” Triclover, Sanitary. (For Material and Head assembly details refer Dwg. No. 99125)

Serial number end          
 Opposite end

**PERMEATE PORT CONFIGURATION:**

- Standard
- 1” Triclover.  
 (For Material and Head assembly details refer Dwg. No. 99125)

For complete information on proper use of the vessel  
 Please refer to the OCTA 80R Series USER'S GUIDE

PORT SIZE CODE	
D	1½” GROOVED END
E	2” GROOVED END
F	2½” GROOVED END

