

300
PSI

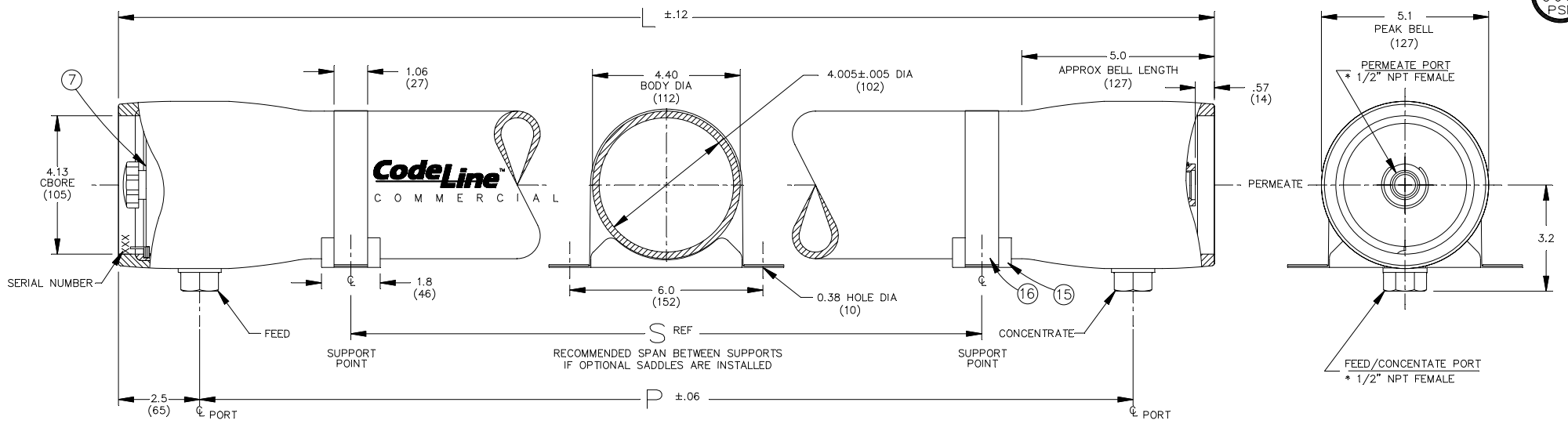

* PARTS LISTED ARE STANDARD OPTIONS

Dwg. Ref.	Qty. Per	* Part Number	Part Name	Materials/Remarks
SHELL				
①	1		Shell	Filament wound epoxy/glass composite. S.S. head locking grooves integrally wound in place. Shell exterior coated with blue high gloss polyurethane paint.
②	2	45147	Feed/Concentrate Port	Fiber Reinforced Thermoplastic
③	2	45303	F/C Port Seal	Ethylene Propylene - O-Ring
④	2	45336	F/C Port Seal, Face	Ethylene Propylene - Square Cut
⑤	2	45251	F/C Port Retainer	302 SST
HEAD				
⑥	1	45140	Bearing Plate	Fiber Reinforced Epoxy Laminate (CONC. END)
⑦	1	50236	Bearing Plate Assy, Blank	Fiber Reinforced Epoxy Laminate (FEED END)
⑧	2	45352	Seal	Ethylene Propylene - Square Cut
⑨	1	50891	Permeate Port	Engineering Thermoplastic
⑩	1	45335	Permeate Part Seal	Ethylene Propylene - Square Cut
⑪	2	45296	PWT Seal	Ethylene Propylene - O-Ring
⑫	1	45242	Port Retainer	302 SST
⑬	1	50903	Permeate Cap, Solid	Engineering Thermoplastic (FEED END ONLY)
HEAD INTERLOCK				
⑭	2	45260	Retaining Ring	302 SST
VESSEL SUPPORT				
⑮	2	45058	Saddle - OPTIONAL	Cast Urethane Elastomer
⑯	2	50329	Strap - OPTIONAL	Type 304 SST - PVC cushion
FOR REFERENCE ONLY				

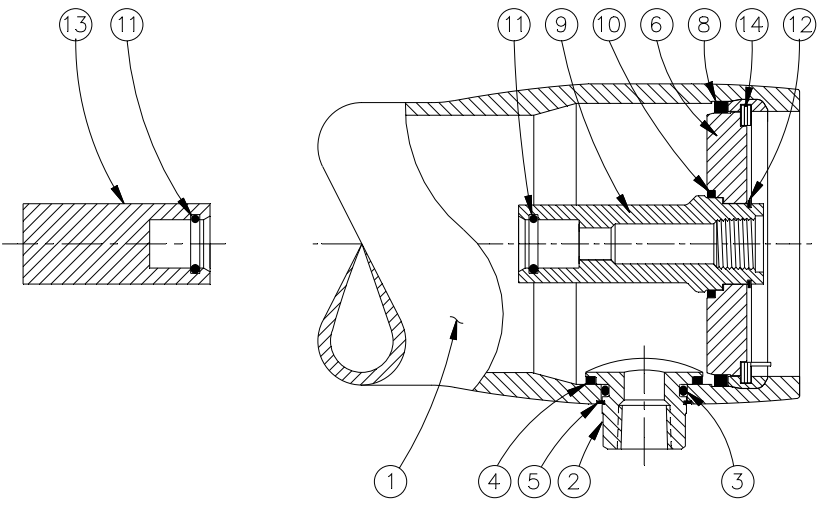

SECTION THROUGH END CLOSURE
DOWNSTREAM END

NOTES
 • DIMENSIONS IN INCHES (MM APPROX)
 • NOT TO BE USED FOR CONSTRUCTION UNLESS CERTIFIED
 • PATENT APPLIED FOR

Shell Length Code	L L.O.A. IN (MM)	P Port to Port IN (MM)	S Span IN (MM)	APPROX. ASSEMBLY Weight LB (KG)
B1	21 (533)	16 (406)	ANY	8.75 (4.0)
C1	28 (711)	23 (584)	9 (229)	10 (4.5)
1	47 (1194)	42 (1067)	28 (711)	13.25 (6.0)
2	87 (2210)	82 (2083)	56 (1422)	19.25 (8.8)
3	127 (3226)	122 (3099)	80 (2032)	26.75 (12.2)

CodeLine
COMMERCIAL
by
CodeLine DIVISION
STRUCTURAL NORTH AMERICA
Escondido, California U.S.A.

ENGR LF 160CT98	MODEL 40C30			
QLTY JK 160CT98	LOW PRESSURE MEMBRANE HOUSING			
MRKT RAU 160CT98	ECO 89387	SHEET 1 OF 1	SIZE B	NUMBER 518002
				REV F

RATING:

DESIGN PRESSURE..... 300 PSI at 176°F
(2.1 MPa at 80°C)
 MIN. OPERATING TEMP..... 20°F
(-7°C)
 FACTORY TEST PRESSURE..... 450 PSI
(3.1 MPa)
 BURST PRESSURE..... 1800 PSI
(12.2 MPa)

INTENDED USE

The Model 40C30 Fiberglass RO/UF Pressure Vessel is designed for continuous, long-term use as a housing for reverse osmosis and ultrafiltration elements in typical commercial water treatment systems at pressures up to 300 psi. Any make of 4-inch nominal diameter spiral-wound element with a 3/4" diameter male product water tube is easily accommodated.

The Model 40C30 must be installed, operated and maintained in accordance with the listed precautions, and good industrial practice to assure safe operation over a long service life.

The high performance reinforced plastic shell must be allowed to expand under pressure; undue restraint at support points or piping connections can cause leaks to develop in the shell. The end closure, incorporating close-fitting, interlocking metal components, must be kept dry and free of corrosion; deterioration can lead to catastrophic mechanical failure of the head assembly.

STRUCTURAL NORTH AMERICA, CodeLine Division will assist the purchaser in determining the suitability of this standard vessel for their specific operating conditions. The final determination however, including evaluation of the standard materials of construction for compatibility with the specific corrosive environment, shall be the responsibility of the purchaser.

Specifications subject to change without notice.

PRECAUTIONS

- DO... read, understand and follow all instructions; failure to take every precaution will void warranty and may result in vessel failure
- DO... mount shell on horizontal or vertical members at central span "S" using compliant vessel supports; tighten hold down straps just snug.
- DO... provide overpressure protection for vessel set at not more than 105% of design pressure
- DO... inspect end closures regularly; replace components that have deteriorated and correct causes of corrosion
- DO NOT...make rigid piping connections to ports or clamp vessel in any way that restricts growth of fiberglass shell under pressure; ▲DIA = 0.01 in. (0.25mm) and ▲L = .03 in. (.8mm) for a length code -1 vessel
- DO NOT...hang piping manifolds from ports or use vessel in any way to support other components
- DO NOT...operate vessel at pressures and temperatures in excess of its rating
- DO NOT... operate vessel without element installed.
- DO NOT... operate vessel with permeate port pressure in excess of 125 PSI (0.9 MPa) at 176°F (80°C)
- DO NOT...tolerate leaks or allow end closures to be routinely wetted in any way
- DO NOT...pressurize vessel until double checking to verify that the retaining rings are in place
- DO NOT...work on any component until first verifying that pressure is relieved from vessel

NOTE

Spiral Retaining Ring Removal Tool (1MM007-1) recommended to open and close vessel.

CAUTION:

EYE PROTECTION SHOULD BE WORN WHEN REMOVING OR INSTALLING RETAINING RINGS.

KEEP FINGERS CLEAR FROM RETAINING RING WHILE INSTALLING LAST OF THREE TURNS.

RING MAY SNAP INTO POSITION POSSIBLY PINCHING FINGERS.

ORDERING

Please specify the following:

- VESSEL MODEL
- MEMBRANE ELEMENT MAKE AND MODEL NUMBER
- SPECIFIC CONCERNS regarding INTENDED USE and requests for SPECIAL MATERIALS of CONSTRUCTION

40C30-

SHELL LENGTH/ELEMENT INTERFACE

Code	Element Capacity
-B1	One 14" Direct Connect
-C1	One 21" Direct Connect
-1	One 40" Direct Connect
-2	Two 40" Direct Connect
-3	Three 40" Direct Connect

SHELL FINISH

Exterior Shell Finish
Blue, high-gloss polyurethane coating

CERTIFICATION

Certification Grade
Certified by CodeLine Division, not ASME Code stamped

OPTIONS

PERMEATE PORT CONFIGURATIONS

Port Sizes
* 1/2" NPT Female
1/2" BSP/JIS Female

FEED/CONC. PORT CONFIGURATIONS

Port Sizes
* 1/2" NPT Female
1/2" BSP/JIS Female

* STANDARD OPTIONS