

600
PSI

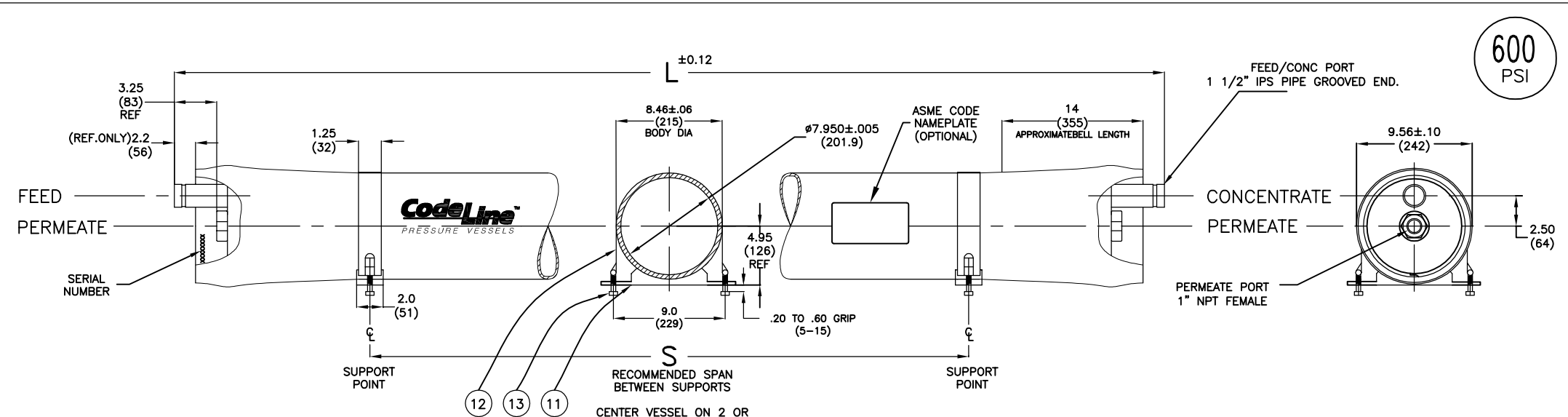

DWG REF	QTY	PART NUMBER	DESCRIPTION	MATERIAL
SHELL				
01	1	ORDER SECTION	SHELL	Filament Wound Epoxy/Glass composites - SS Head locking grooves integrally wound in place.
HEAD				
02	2	51052	Bearing Plate	6061-T6 Aluminium Alloy-Hard Anodized.
03	2	96003	Sealing Plate	Engineering Thermoplastic.
04	2	50567	Feed/Conc Port	316L Stainless Steel.
05	2	45090	Port Retainer Set	CF8M Cast SS, Two-piece set.
06	2	50569	Permeate Port	Engineering Thermoplastic.
07	2	45066	Port Nut	Engineering Thermoplastic.
08	2	96000	Head Seal	Ethylene Propylene - O Ring.(442)
09	4	45312	Port Seal	Ethylene Propylene - O Ring.(225)
HEAD INTERLOCK				
10	2	47336	Retaining Ring	316 Stainless Steel.
VESSEL SUPPORT				
11	*2	52169	Saddle	Engineering Thermoplastic.
12	*2	45042	Strap Assy.	304 Stainless Steel - PVC cushion
13	4	46265	Strap screw.	5/16-18 UNC, 18-8 Stainless Steel.
ELEMENT INTERFACE				
14	2	A/R	Adapter	Engineering Thermoplastic.
15	4	A/R	PWT Seal	Ethylene Propylene - O - Ring
16	2	52245	Adapter seal	Ethylene Propylene - O - Ring (124)
17	1	45069	Thrust Ring	Engineering Thermoplastic.

* 3 Each Furnished With Length Code 4, 5, 6 & 7.

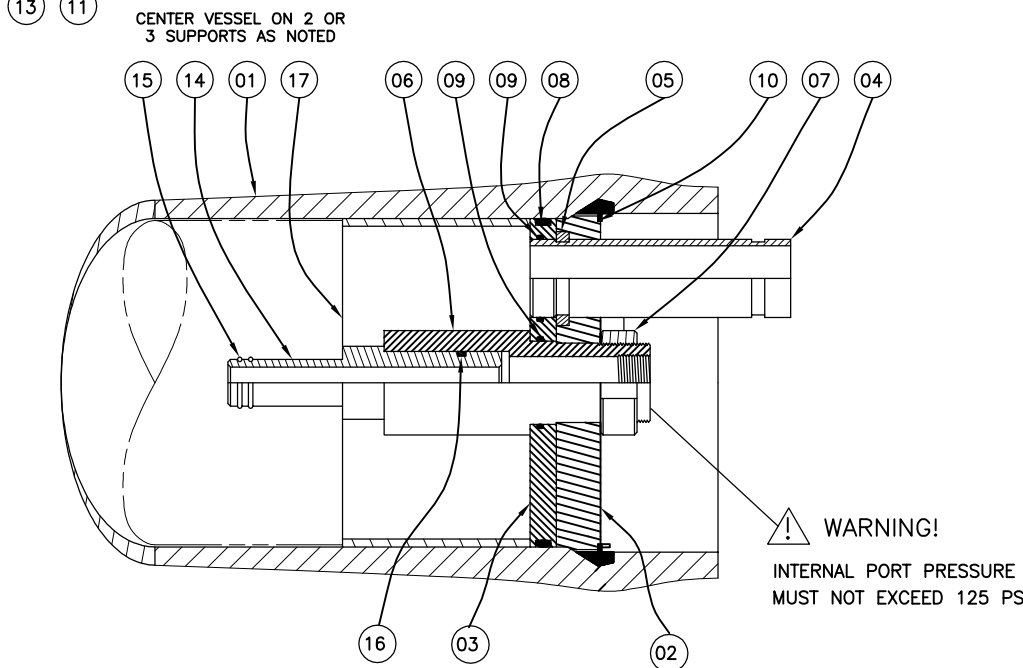

Shell Length Code	L L.O.A. IN (MM)	S Span IN (MM)	Empty Weight LB (KG)
1	63 (1600)	30 X 1 (762)	50 (23)
2	103 (2616)	70 X 1 (1778)	70 (32)
3	143 (3632)	110 X 1 (2794)	90 (41)
4	183 (4648)	75 X 2 (1905)	110 (50)
5	223 (5664)	95 X 2 (2413)	130 (59)
6	263 (6680)	115 X 2 (2921)	150 (68)
7	303 (7696)	135 X 2 (3429)	170 (77)

WARNING!
INTERNAL PORT PRESSURE MUST NOT EXCEED 125 PSI



NOTES
 *SHELL EXTERIOR COATED WITH WHITE, HIGH GLOSS POLYURETHANE PAINT
 *DIMENSIONS ARE IN INCHES (MM APPROX.)
 *NOT TO BE USED FOR CONSTRUCTION UNLESS CERTIFIED
 *GENERAL TOLERANCES APPLY. FOR DETAILS CONTACT FACTORY
 *L.O.A REFERS TO OVERALL LENGTH OF THE VESSEL.
 *EMPTY WEIGHT REFERS TO SHELL WEIGHT INCLUDING HEAD ASSEMBLIES WITHOUT MEMBRANES.

SECTION THROUGH END CLOSURE

ITEM 17 DOWNSTREAM ONLY

ENGR	IS	MODEL 80E60 MEMBRANE HOUSING				
QTY	HP					
DATE 30DEC09	SCALE	SHEET	SIZE	NUMBER	REV	
ECN : 1719	NONE	1 OF 2	B	99109	H	

RATING:

DESIGN PRESSURE.....600 PSIG at 120°F
(4.14 Mpa @ 49°C)
MIN. OPERATING TEMP.....20°F
(-7°C)
FACTORY TEST PRESSURE.....CE / ASME
900 / 780 PSIG
(6.2Mpa) / (5.4 MPa)
BURST PRESSURE.....3600 PSIG
(24.8 MPa)

INTENDED USE:

The CodeLine Model 80E60 Fiberglass RO Pressure Vessel is designed for continuous, long term use as a housing for reverse osmosis membrane elements to desalt typical brackish waters at pressures up to 600 psi. Any make of eight-inch nominal diameter spiral-wound element is easily accommodated; the appropriate interfacing hardware for the element specified is furnished with the vessel.

The CodeLine Model 80E60 is designed in accordance with the engineering standards of the Boiler and Pressure Vessel Code of the American Society of Mechanical Engineers (ASME Code). At small additional cost, vessels can be inspected during construction by an ASME Authorized inspector and ASME Code stamped.

The CodeLine Model 80E60 must be installed operated and maintained in accordance with the listed precautions and good industrial practice to assure safe operation over a long service life.

The high performance reinforced plastic shell must be allowed to expand under pressure; undue restraint at support points or piping connections can cause leaks to develop in the shell. The end closure, incorporating close fitting, interlocking metal components, must be kept dry and free of corrosion; deterioration can lead to catastrophic mechanical failure of the head.

The end closures, incorporating close-fitting, interlocking metal components, must be kept dry and free of corrosion; deterioration can lead to catastrophic mechanical failure of the heads.

Pentair Water will assist the purchaser in determining the suitability of this standard vessel for their specific operating conditions. The final determination however, including evaluation of the standard material of construction for compatibility with the specific corrosive environment, shall be the responsibility of the purchaser.

Specifications are subject to change without notice.

PRECAUTIONS:

- DO...read, understand and follow all instructions; failure to take every precaution will void warranty and may result in vessel failure
- DO...mount the shell on horizontal members at span "S" using complaint vessel supports furnished; tighten hold down straps just snug
- DO...provide overpressure protection for vessel set at not more than 105% of design pressure
- DO...inspect end closures regularly; replace components that have deteriorated and correct causes of corrosion
- DO NOT... make rigid piping connections to ports or clamp vessel in any way that resists growth of fiberglass shell under pressure; ΔDIA = 0.015 in. (0.4mm) and ΔL = 0.2 in. (5mm) for a length code -7 vessel
- DO NOT... hang piping manifolds from ports or use vessel in any way to support other components; branch connection piping may be simply supported between the header and port; maximum weight of branch piping; feed/concentrate – 16 lbs (7.3 kg); permeate – 8 lbs (3.6 kg)
- DO NOT... operate vessel at pressures and temperatures in excess of its rating
- DO NOT... operate vessel without permeate ports internally connected with a complete set of elements and interconnecting hardware
- DO NOT... operate vessel with permeate pressure in excess of 125 psi at 120°F (0.86 MPa @ 49°C)
- DO NOT... overtighten the connection to the permeate port (hand-tighten plus one-quarter turn, check for leaks)
- DO NOT... tolerate leaks or allow end closures to be routinely wetted in any way
- DO NOT... pressurize vessel until double-checking to verify that the retaining ring is completely inside the groove
- DO NOT... work on any component until first verifying that pressure is relieved from vessel
- DO NOT... operate at pH levels below 3 or above 10

ORDERING:

Using the chart below, please check the features you require and fax them with your purchase order to our customer service department for expedited processing.
For optional materials and/or features not listed below, please consult factory for pricing and availability.

Please note that we require your membrane brand and model number when ordering. If this information is not initially available, you may provide it at a later date by checking the appropriate box below.

VESSEL LENGTH CODE – please check one

MODEL 80E60 -1 -2 -3 -4 -5 -6 -7

MEMBRANE BRAND AND MODEL – please check one and fill in information

Please supply adapters for the following membrane brand and specific model
Brand _____ Model _____

CERTIFICATION REQUIRED

- ASME Stamped and National Board Registered (please consult factory for pricing)
- CE Marked
- Standard, Certified by Pentair water.

EXTERIOR FINISH – please check one

- Standard – white high-gloss polyurethane coating.
- Option – optional colors are available for 50 or more vessels per order.
Call factory for pricing details.

MATERIAL OPTIONS

- Standard – All materials as per drawing 99109 on the first page.
- Customer specified materials: -
(Please consult the factory, as these options will affect pricing and vessel lead-time.)

For complete information on proper use of this vessel please refer to the 80E series USER'S GUIDE Bulletin 523004.