

450
PSI

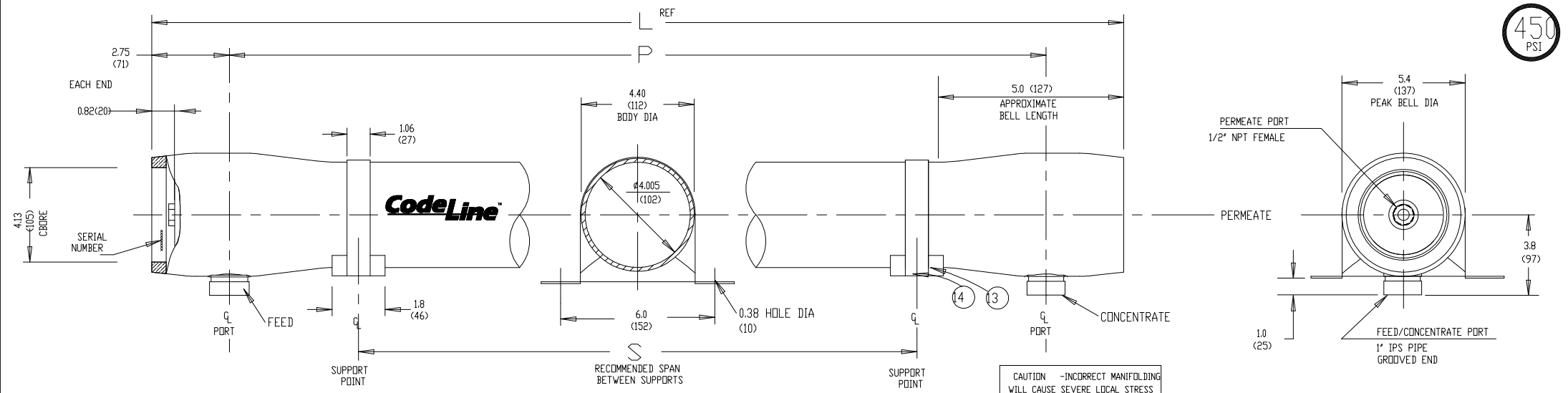

VIEW AT CENTER SUPPORT
CENTER VESSEL ON 2 OR 3 SUPPORTS
AT SPAN(S) *S*3 SUPPORTS REQUIRED
FOR LENGTHS -4 AND OVER

Dwg. Ref.	Qty. Per	Part Number	Description	Materials/Remarks
SHELL				
①	1		Shell	Filament wound epoxy/glass composite- S.S Head locking grooves integrally wound in-place, with white high gloss polyurethane paint
②	2		F/C Port	316 SST
③	2	47135	F/C Port Seal	Ethylene Propylene - square cut
④	2	45251	F/C Port Retainer	300 series SST
HEAD				
⑤	2	45140/98061	Bearing Plate	Fiber Reinforced Epoxy Laminate/
⑥	2	45352	Bearing Plate(optional)	316L SS as optional on ASME coded vessels
⑦	2	50898	Plate Seal	Ethylene Propylene - Square Cut
⑧	2	45335	Permeate Port	Engineering Thermoplastic
⑨	2	45335	Permeate Port Seal	Ethylene Propylene - Square Cut
⑩	4	45296	PWT/Adapter Seal	Ethylene Propylene - O-ring
⑪	2	As required	Adapter	Engineering Thermoplastic
⑪	2	45242	Port Retainer	300 Series SST
HEAD INTERLOCK				
⑫	2	45260	Retaining Ring	316L SST
VESSEL SUPPORT				
⑬	*3	45058	Saddle	Cast Urethane Elastomer
⑭	*3	47459	Strap	304 Stainless Steel - PVC cushion
*2 each furnished with length code 1, 2 & 3				
FOR REFERENCE ONLY				

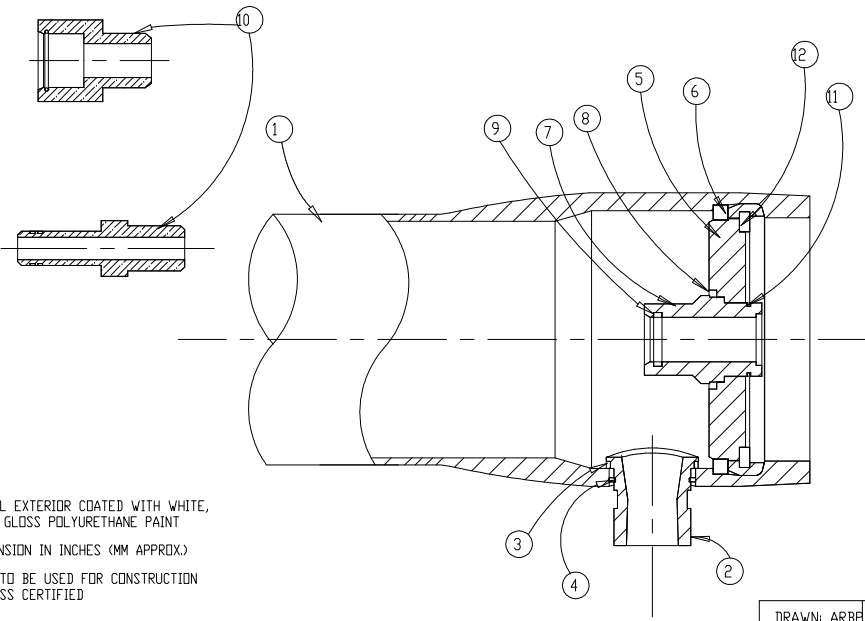

- NOTES
- SHELL EXTERIOR COATED WITH WHITE, HIGH GLOSS POLYURETHANE PAINT
 - DIMENSION IN INCHES (MM APPROX.)
 - NOT TO BE USED FOR CONSTRUCTION UNLESS CERTIFIED

Shell Length Code	L L.O.A. IN (MM)	P Span IN (MM)	S Span IN (MM)	Approx. Weight LB (KG)
1	47.5 (1206)	42 (1067)	28 X 1 (711)	13.25 (6.0)
2	87.5 (2222)	82 (2083)	56 X 1 (1422)	19.25 (8.8)
3	127.5 (3238)	122 (3099)	80 X 1 (2032)	26.75 (12.2)
4	167.5 (4254)	162 (4115)	64 X 2 (1626)	34.25 (15.6)
5	207.5 (5270)	202 (5131)	78 X 2 (1981)	41.75 (19.0)
6	247.5 (6286)	242 (6147)	92 X 2 (2337)	49.25 (22.4)



DRAWN: ARBF	MODEL 40A45 MEMBRANE HOUSING				
CHECKED: SM					
SCALE: NONE	ECN 575	SHEET 1 OF 2	SIZE A3	NUMBER 99127	REV E

SECTION THROUGH END CLOSURE

ENDS ARE IDENTICAL

RATING:

DESIGN PRESSURE..... 450 PSIG at 176°F
(3.1 MPa at 80°C)

NOTE: FOR 316L SS BEARING PLATE...450 PSI AT 190°F *
(3.1 MPa at 88°C)

MIN. OPERATING TEMP..... 20°F
(-7°C)

FACTORY TEST PRESSURE..... 495 PSIG
(3.45 MPa)

BURST PRESSURE..... 2700 PSIG
(18.6 MPa)

INTENDED USE

The CodeLine Model 40A45 Fiberglass RO Pressure Vessel is designed for continuous, long-term use as a housing for reverse osmosis membrane elements to desalt typical brackish waters at pressures up to 450 psi. Any make of four-inch nominal diameter spiral-wound element is easily accommodated; the appropriate interfacing hardware for the element specified is furnished with the vessel.

The CodeLine Model 40A45 is designed in accordance with the engineering standards of the Boiler and pressure Vessel Code of the American Society of Mechanical Engineers (ASME Code). At small additional cost vessels can be inspected during construction by an ASME Authorized Inspector and ASME Code stamped.

The CodeLine Model 40A45 must be installed, operated and maintained in accordance with the precautions listed and good industrial practice to assure safe operation over a long service life.

The high performance reinforced plastic shell must be allowed to expand under pressure; undue restraint at support points or piping connections can cause leaks to develop in the shell. This side-ported vessel requires special precautions in mounting and connection to piping so that the vessel will not be subjected to excessive stress due to bending moments acting at the side openings in the fiberglass shell.

The end closures, incorporating close-fitting, interlocking metal components, must be kept dry and free of corrosion; deterioration can lead to catastrophic mechanical failure of the heads.

Pentair Water will assist the purchaser in determining the suitability of this standard vessel for their specific operating conditions. The final determination however, including evaluation of the standard materials of construction for compatibility with the specific corrosive environment, shall be the responsibility of the purchaser. Alternate materials with enhanced corrosion resistance are available on special order.

* For Sanitary option also (Drg.No:-99129) the operating temperature can be 190°F (88°C).

PRECAUTIONS

- DO... read, understand and follow all instructions; failure to take every precaution will void warranty and may result in vessel failure
- DO... mount shell centered on horizontal members spaced at recommended span(s) ' ' using compliant mounting hardware furnished; tighten hold down straps just snug
- DO... align and center side ports with the manifold header; correct causes of misalignment in a row of vessels connected to the same header
- DO... use flexible type grooved-end pipe couplings, Victaulic ® Style 75 or equal, at sideports; allow full .125 inch gap between port and piping, and position piping to maximize flexibility of connection
- DO... provide flexibility in, and support for piping manifold so that vessel can grow in length under pressure without undue restraint; provide additional flexible joints in large pipes leading to manifold header
- DO... provide overpressure protection for vessel set at not more than 105% of design pressure
- DO... inspect end closures regularly; replace components that have deteriorated and correct causes of corrosion
- DO NOT... work on any component until first verifying that pressure is relieved from vessel
- DO NOT... make rigid piping connections to ports or clamp vessel in any way that restricts growth of fiberglass shell under pressure; DIA = 0.015 in. (0.4mm) and ΔL = 0.2 in. (6mm) for a length code -8 vessel
- DO NOT... hang piping manifolds from ports or use vessel in any way to support other components
- DO NOT... tighten Permeate Port connection more than one turn past hand tight
- DO NOT... operate vessel without connecting both Permeate Ports internally to a complete set of elements or otherwise plug ports internally so that external piping connection is not subjected to feed pressure
- DO NOT... install Spacer on downstream end of vessel
- DO NOT... operate vessel without Thrust Cone installed downstream
- DO NOT... pressurize vessel until double checking to verify that the Retaining Ring is in place and fully seated.
- DO NOT... operate vessel at pressures and temperatures in excess of its rating
- DO NOT... operate vessel with permeate pressure in excess of 125 psi at 120°F (0.9 MPa at 49°C)
- DO NOT... tolerate leaks or allow end closures to be routinely wetted in any way
- DO NOT... operate at pH levels below 3 or above 10

ORDERING

Using the chart below, please check the features you require and fax them with your purchase order to our customer service department for expedited processing. For optional materials and or feature not listed below, please consult the factory for pricing and availability.

VESSEL LENGTH CODE - please check one
MODEL 40A45 -1 -2 -3 -4 -5 -6

EXTERIOR FINISH - please check one
 Standard - white high-gloss polyurethane coating over sanded surface.
 Option - optional colors are available for 50 or more vessels per order. Call factory for pricing details.

MEMBRANE BRAND AND MODEL - please check one and fill in information
 Please supply adapters for the following membrane brand and specific model.
Brand _____ Model _____

Membrane brand and model information is not currently available, but will be supplied to CodeLine on or before the following date ___/___/___

MATERIAL AND PORT CONFIGURATIONS OPTIONS - please check one
 Standard - all materials and port configurations per drawing 99127 on the opposite page.
NOTE: The options listed below will increase the vessel price. Call factory for pricing details.

Option Customer specified port configurations using the chart below, please indicate the custom options you require for each end of the pressure vessel (many options are required only at one end). Please consult the factory as these options will affect pricing and vessel lead time.

PERMEATE PORT CONFIGURATION

- Standard - 1/2" NPTF
- Optional -3/4" SANITARY TRICLOVER

PORT SIZE CODE	
C	1 1/2" GROOVED END

FEED PORT CONFIGURATION

- Standard - 1" IPS pipe, grooved ends, with ports in-line
 - Optional - Multi-Ports
- Using the instructions in CodeLine Bulletin #507054 please fill out your feed port configuration in the space below. Ports not available in 90° configurations. List port location first followed by port size for each choice.

Serial number end

Opposite end

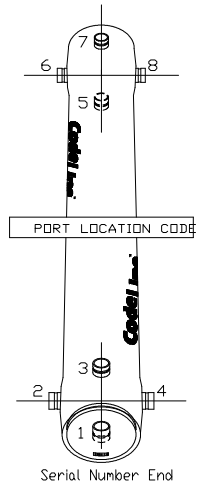

For complete information on proper use of this vessel please refer to the 40A Series USER'S GUIDE,

Specifications subject to change without notice.