

Dwg. Ref.	Qty. Per	Part Number	Part Name	Materials/Remarks
SHELL				
01	1		Shell Length	Filament wound epoxy/glass Composite-Head locking grooves integrally wound-in-place
02	A/R	ORDER	Feed/Conc Port	CF3M#
03	A/R	SECTION	Retaining Ring,	SS316/Equivalent
04	A/R		Seal, Feed/Conc Port,	Ethylene Propylene
HEAD				
05	2	96309	Bearing Plate	6061-T6 aluminium alloy
06	2	96311	Sealing Plate	Engineering Thermoplastic
07	2	96312	Permeate Port	Engineering Thermoplastic
08	2	96220	Port Nut	Engineering Thermoplastic
09	2	96224	Head Seal(s)	Ethylene Propylene
10	2	96223	Permeate Port Seal	Ethylene Propylene
11	4	96215	Lifting Handle	SS 316
12	8	96403	M14 Allen Head Screw	SS 316
HEAD INTERLOCK				
13	8	96219	Locking Segments	SS 316
14	16	96387	Allen Head Screw	SS 316
VESSEL SUPPORT				
15	2*	96216	Saddle	Engineering Thermoplastic
16	2*	94193	Strap Assy	304 Stainless Steel-PVC Cushion.
ELEMENT INTERFACE				
17	2	96223	Adapter Seal	Ethylene Propylene-O-Ring
18	4	96204	PWT Seal	Ethylene Propylene-O-Ring
19	2	A/R	Adapter	Engineering Thermoplastic
20	1	96316	Thrust Ring	Engineering Thermoplastic

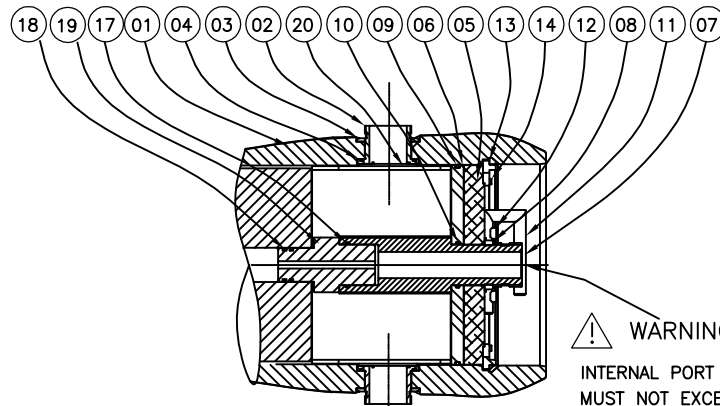

CAUTION: INCORRECT MANIFOLDING WILL CAUSE SEVERE LOCAL STRESS AROUND PORT AND MAY RESULT IN LEAKS AND PREMATURE FAILURE; TAKE EVERY PRECAUTION LISTED ON REVERSE, SEE INSTALLATION INSTRUCTIONS FOR FURTHER DETAILS

WARNING !
INTERNAL PORT PRESSURE MUST NOT EXCEED 125 PSI

SECTION THROUGH DOWNSTREAM END
ITEM 20 DOWNSTREAM ONLY.

- NOTES:
- 1) DIMENSIONS ARE IN INCHES (MM APPROX)
 - 2) DIMENSIONS SUBJECT TO CHANGE NOT TO BE USED FOR CONSTRUCTION UNLESS CERTIFIED.
 - 3) GENERAL TOLERANCES APPLY CONTACT FACTORY FOR DETAILS.
 - 4) SHELL IS DESIGNED TO ACCOMODATE BOTH 40" & 40.5" MEMBRANES.
 - 5) #GRADE CF3M AS PER ASME SA-351.
 - 6) NO ADAPTERS WILL BE SUPPLIED BY PENTAIR FOR DOW MEMBRANE FOR DETAILS REFER PAGE 2.
 - 7) *3 EACH FURNISHED WITH LENGTH CODE 4,5,6,7&8.
 - 8) SHELL EXTERIOR COATED WITH WHITE, HIGH GLOSS POLYURETHANE PAINT.

Dash Length	L IN(MM)	P IN(MM)	S IN(MM)	Approx Weight LB(KG)
-1	80.31 (2040)	55.5 (1410)	28X1 (711)	444 (201)
-2	120.81 (3069)	96 (2438)	56X1 (1422)	524 (237)
-3	161.31 (4097)	136.5 (3467)	80X1 (2032)	603 (273)
-4	201.81 (5126)	177 (4496)	64X2 (1626)	683 (309)
-5	242.31 (6155)	217.5 (5525)	78X2 (1981)	763 (346)
-6	282.81 (7183)	258 (6553)	92X2 (2337)	843 (382)
-7	323.31 (8212)	298.5 (7582)	106X2 (2692)	922 (418)
#-8	363.81 (9241)	339 (8611)	120X2 (3048)	1002 (454)

CodeLine™
Pentair Water

CODELINE 160S30
MEMBRANE HOUSING

DRAWN	KR	DATE	07NOV08
CHECKED	KR	DATE	07NOV08
APPROVED	SS	DATE	07NOV08

DATE	23JUN10	DWG. NO.	99178	REV.	F
ECN	1875	SCALE	NONE	SIZE	A3
			SHEET	1 OF 2	

RATING:

DESIGN PRESSURE.....300 PSIG at 120°F
 (2.06 MPa at 49°C)
 MIN. OPERATING TEMP.....20°F
 (-7°C)
 FACTORY TEST PRESSURE... ..390 PSIG
 (2.7 MPa)
 QUALIFICATION PRESSURE1800 PSI
 (12.4 MPa)

INTENDED USE:

The CodeLine 160S30 Fiberglass RO Pressure Vessel is designed for continuous, long term use as a housing for reverse osmosis membrane elements to desalt typical brackish waters at pressures up to 300 psi. Any make of Sixteen-inch nominal diameter spiral-wound element is easily accommodated; the appropriate interfacing hardware for the element specified is furnished with the vessel.

The CodeLine 160S30 is designed in accordance with the engineering standards of the Boiler and Pressure Vessel Code of the American Society of Mechanical Engineers (ASME) Code.

The CodeLine 160S30 must be installed, operated and maintained in accordance with the listed precautions and good industrial practice to assure safe operation over a long service life.

The high performance Filament wound FRP shell must be allowed to expand under pressure; undue restraint at support points or piping connections can cause leaks to develop in the shell. This side-ported vessel requires special precautions in mounting and connection to piping so that the vessel will not be subjected to excessive stress due to bending moments acting at the side openings in the fiberglass shell. The end closure, incorporating close fitting, interlocking metal components, must be kept dry and free of corrosion; deterioration can lead to catastrophic mechanical failure of the head.

Pentair Water will assist the purchaser in determining the suitability of this standard vessel for their specific operating conditions. The final determination however, including evaluation of the standard material of construction for compatibility with the specific corrosive environment, shall be the responsibility of the purchaser. Alternate materials with enhanced corrosion resistance are available on special order.

Specifications are subject to change without notice.

PRECAUTIONS:

- DO...read, understand and follow all instructions; failure to take every precaution will void warranty and may result in vessel failure
- DO...mount the shell on horizontal members at span “S” using compliant vessel supports furnished; tighten hold down straps just snug
- DO...align and center side ports with the manifold header. Correct, causes of misalignment in a row of vessels connected to the same header
- DO...use flexible type grooved-end pipe couplings, Victaulic® Style 77 or equal, at side ports; allow full, 0.125 inch gap between port and piping, and position piping to maximize flexibility of connection.
- DO...provide flexibility in, and support for piping manifolds so that vessel can grow in length under pressure without undue restraint; provide additional flexible joints in large pipes leading to manifold header.
- DO...provide overpressure protection for vessel set at not more than 105% of design pressure
- DO...inspect end closures regularly; replace components that have deteriorated and correct causes of corrosion
- DO...Lubricate seals sparingly, using nonpetroleum based lubricants, i.e. Parker Super O-lube® Glycerin or suitable silicone based lubricants.
- DO NOT...work on any component until first verifying that pressure is relieved from vessel
- DO NOT...make rigid piping connections to ports or clamp vessel in any way that resists growth of fiberglass shell under pressure;
 ***ΔDIA = 0.015 in. (0.4mm) and
 ***ΔL = 0.2 in. (6mm) for a length code –8 vessel
- DO NOT... hang piping manifolds from ports or use vessel in any way to support other components
- DO NOT...tighten Permeate Port connection more than one turn past hand tight
- DO NOT... operate vessel without connecting both Permeate Ports internally to complete set of elements or otherwise plug ports internally so that external piping connection is not subjected to feed pressure
- DO NOT...install Spacer on downstream end of vessel
- DO NOT...operate vessel without Thrust Ring installed downstream
- DO NOT...pressurize vessel until double-checking to verify that the Locking Ring is in place and fully seated.
- DO NOT...operate vessel at pressure and temperature in excess of its rating.
- DO NOT...operate vessel with permeate pressure in excess of 125 psi at 120°F (0.86 Mpa at 49°C).
- DO NOT...tolerate leaks or allow end closures to be routinely wetted in any way
- DO NOT...operate outside the pH range 3-10.

ORDERING:

Using the chart below, please check the features you require and fax them with your purchase order to our customer service department for further processing. For optional materials and / or feature not listed below, please consult the factory for pricing and availability

VESSEL LENGTH CODE – please check one

MODEL 160S30 -1 -2 -3 -4 -5 -6 -7 -8
 # Consult Sales manager for Eight Element housings.

MEMBRANE BRAND AND MODEL – please check one and fill in information

- Please supply adapters for the following membrane brand and specific model
 Brand _____ Model _____
- Membrane brand and model information is not currently available, but will be supplied to Pentair Water on or before the following date. ___ / ___ / ___

CERTIFICATION REQUIRED

- Standard, Certified by Pentair water.

MATERIAL OPTIONS – please check one

- Standard: all materials and port configurations as per drawing 99178 on the previous page
- Option: Customer specified Material of Construction. (Please consult factory as these options will affect pricing and vessel lead time)

FEED/CONCENTRATE PORT CONFIGURATION

- Standard – 3” IPS pipe, grooved ends, with ports in-line
- Optional – Multi-Ports™
 Using the instructions in Order Specification Sheet
 Please fill out your feed port configuration in the space below.
 List port location first, followed by port size for each choice.
 Ports not available in 90° configurations.
 (Please consult factory as these options will affect pricing and vessel lead time)

Serial number end
 Opposite end

PORT SIZE CODE	
G	3” GROOVED END
I	4” GROOVED END
K	6” GROOVED END

PERMEATE PORT CONFIGURATION:

- Standard 3” MNPT.

PERMEATE PORT FOR 40.5” DOW MEMBRANES

- Use 96967 Perm port & 96968 Thrust Ring

For complete information on proper use of the vessel Please refer to the 160” Series USER’S GUIDE 99347

