

Dwg. Ref.	Qty. Per	Part Number	Part Name	Materials/Remarks
<b>SHELL</b>				
01	1		Shell Length	Filament wound epoxy/glass composite-Head locking grooves integrally wound in-place
<b>HEAD</b>				
02	2	96210	Bearing Plate	6061-T6 aluminium alloy -Hard Anodized
03	2	96225	Sealing Plate	Engineering Thermoplastic
04	2	96211	Feed/Conc Port	Zeron-100*
05	2	96217	Port Retainer Set	SS 316 OR CAST EQUIVALENT
06	2	96212	Permeate Port	Engineering Thermoplastic
07	2	96220	Port Nut	Engineering Thermoplastic
08	2	96224	Head Seal	Ethylene Propylene - O-Ring
09	2	96223	Permeate Port Seal	Ethylene Propylene - O-Ring
10	2	96223	Feed Concentrate Port Seal	Ethylene Propylene - O-Ring
11	4	96215	Lifting Handle	SS 316
12	8	96403	M14 Allen Head Screw	SS 316
<b>HEAD INTERLOCK</b>				
13	8	96209	Locking Segments	SS 316 OR CAST EQUIVALENT
14	16	96387	Allen Head Screw	SS 316
<b>VESSEL SUPPORT</b>				
15	2*	96216	Saddle	Engineering Thermoplastic
16	2*	94187	Strap Assy	304 Stainless Steel
<b>ELEMENT INTERFACE</b>				
17	2	96223	Adapter Seal	Ethylene Propylene - O-Ring
18	4	A/R	PWT Seal	Ethylene Propylene - O-Ring
19	2	A/R	Adapter	Engineering Thermoplastic
20	1	96228	Thrust Ring	Engineering Thermoplastic

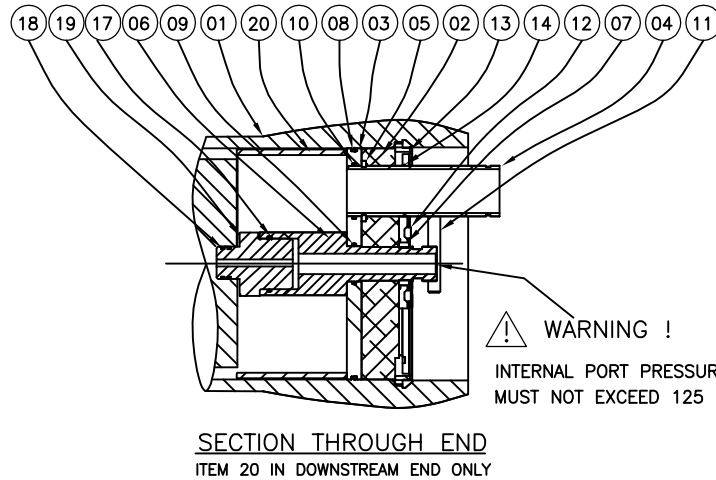

**NOTES:**

- 1) DIMENSIONS ARE IN INCHES (MM APPROX)
- 2) DIMENSIONS SUBJECT TO CHANGE NOT TO BE USED FOR CONSTRUCTION UNLESS CERTIFIED
- 3) GENERAL TOLERANCES APPLY, CONTACT FACTORY FOR DETAILS.
- 4) SHELL IS DESIGNED TO ACCOMMODATE BOTH 40" & 40.5" MEMBRANES.
- 5) ALTERNATIVE MATERIAL 3"SCH 40 PIPE SAF-2507.
- 6) NO ADAPTERS WILL BE SUPPLIED BY PENTAIR FOR DOW MEMBRANES. FOR DETAILS REFER PAGE 2.
- 7) SHELL EXTERIOR COATED WITH WHITE, HIGH GLOSS POLYURETHANE PAINT.
- 8) \*3 EACH FURNISHED WITH LENGTH CODE 4,5,6,7&8.

Dash Length	L IN(MM)	S IN(MM)	Approx Weight LB(KG)
-1	81.9 (2081)	28X1 (711)	777 (352)
-2	122.4 (3110)	56X1 (1422)	964 (437)
-3	162.9 (4139)	80X1 (2032)	1150 (522)
-4	203.4 (5167)	64X2 (1626)	1337 (606)
-5	243.9 (6196)	78X2 (1981)	1524 (691)
-6	284.4 (7225)	92X2 (2337)	1711 (776)
-7	324.9 (8253)	106X2 (2692)	1898 (861)
# -8	365.4 (9282)	120X2 (3048)	2085 (946)

**CodeLine™**  
Pentair Water

**CODELINE 160E120 MEMBRANE HOUSING**

DRAWN	KR	DATE	DWG. NO.	REV.
CHECKED	KR	23JUN10	99024	J
APPROVED	RM	ECN 1875	SCALE NONE	SIZE A3
			SHEET 1 OF 2	

**RATING:**

DESIGN PRESSURE.....1200 PSI at 120°F  
(8.27 MPa @ 49°C)  
MIN. OPERATING TEMP.....20°F  
(-7°C)  
FACTORY TEST PRESSURE..... 1560 PSI  
(10.8 MPa)  
BURST PRESSURE.....7200 PSI  
(49.6 MPa)

**INTENDED USE:**

The CodeLine 160E120 Fiberglass RO Pressure Vessel is designed for continuous, long term use as housing for reverse osmosis membrane elements to desalt typical brackish waters at pressures up to 1200 psi. Any make of Sixteen-inch nominal diameter spiral-wound element is easily accommodated; the appropriate interfacing hardware for the element specified is furnished with the vessel.

The CodeLine 160E120 is designed in accordance with the engineering standards of the Boiler and Pressure Vessel Code of the American Society of Mechanical Engineers (ASME) Code.

The CodeLine 160E120 must be installed, operated and maintained in accordance with the listed precautions and good industrial practice to assure safe operation over a long service life.

The high performance Filament wound FRP shell must be allowed to expand under pressure; undue restraint at support points or piping connections can cause leaks to develop in the shell. The end closure, incorporating close fitting, interlocking metal components, must be kept dry and free of corrosion; deterioration can lead to catastrophic mechanical failure of the head.

Pentair Water will assist the purchaser in determining the suitability of this standard vessel for their specific operating conditions. The final determination however, including evaluation of the standard material of construction for compatibility with the specific corrosive environment, shall be the responsibility of the purchaser. Alternate materials with enhanced corrosion resistance are available on special order.

Specifications are subject to change without notice

**PRECAUTIONS:**

- DO...read, understand and follow all instructions; failure to take every precaution will void warranty and may result in vessel failure
- DO...mount the shell on horizontal members at span "S" using compliant vessel supports furnished; tighten hold down straps just snug
- DO...provide overpressure protection for vessel set at not more than 105% of design pressure
- DO...inspect end closures regularly; replace components that have deteriorated and correct causes of corrosion
- DO...Lubricate seals sparingly, using nonpetroleum based lubricants, i.e. Parker Super O-lube® Glycerin or suitable silicone based lubricants.
- DO NOT... make rigid piping connections to ports or clamp vessel in any way that resists growth of fiberglass shell under pressure; ΔDIA = 0.02 in. (0.5mm) and ΔL = 0.2 in. (5mm) for a length code -6 vessel
- DO NOT... hang piping manifolds from ports or use vessel in any way to support other components; branch connection piping may be simply supported between the header and port; maximum weight of branch piping; feed/concentrate – 16 lbs (7 kg); permeate – 8 lbs (4 kg)
- DO NOT... operate vessel at pressures and temperatures in excess of its rating
- DO NOT... operate vessel without permeate ports internally connected with a complete set of elements and interconnecting hardware
- DO NOT... operate vessel with permeate pressure in excess of 125 psi at 120°F (0.9 MPa @ 49°C)
- DO NOT... overtighten the connection to the permeate port (hand-tighten plus one-quarter turn, check for leaks)
- DO NOT... tolerate leaks or allow end closures to be routinely wetted in any way
- DO NOT... pressurize vessel until double-checking to verify that the retaining ring is completely inside the groove
- DO NOT... work on any component until first verifying that pressure is relieved from vessel
- DO NOT... operate at pH levels below 3 or above 10

**ORDERING:**

Using the chart below, please check the features you require and fax them with your purchase order to our customer service department for expedited processing. For optional materials and/or features not listed below, please consult factory for pricing and availability.

**VESSEL LENGTH CODE**

MODEL 160E120 □-1 □-2 □-3 □-4 □-5 □-6 □-7 □-8  
#Consult Sales manager for Eight Element Housings.

**CERTIFICATION REQUIRED**

Standard, Certified by Pentair Water.

**MEMBRANE BRAND AND MODEL** –Please check one and fill in the required information

- Please supply adapters for the following membrane brand and specific model  
Brand \_\_\_\_\_ Model \_\_\_\_\_
- Membrane brand and model information is not currently available, but will be supplied to Pentair Water on or before the following date.  
\_\_\_ / \_\_\_ / \_\_\_

**MATERIAL OPTIONS**

- Standard – All materials as per drawing 99024 on the first page.
- Customer specified material of construction.  
(Please consult the factory, as these options will affect pricing and vessel lead-time.)

**PERMEATE PORT FOR 40.5” DOW MEMBRANES**

Use 96956 Perm port & 96957 Thrust Ring

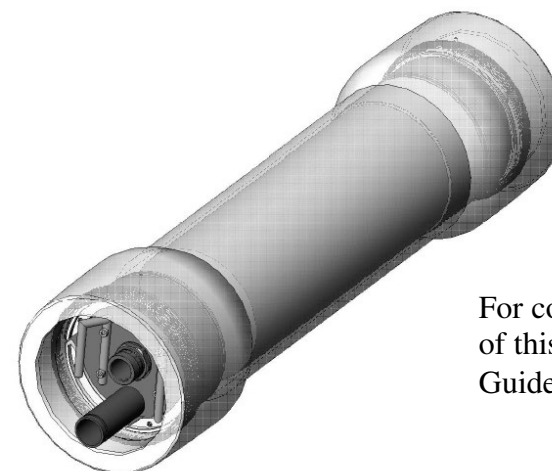

For complete information on the proper use of this vessel please refer to the 16” User Guide Bulletin No. 94347